

HAUTEUR TOTALE	PANNEAU MESURE	ENTRE POTEAUX	CENTRE/ CENTRE
24-72	96 ½"	100 ½"	103 ½"
84+	67 ½"	71"	74"

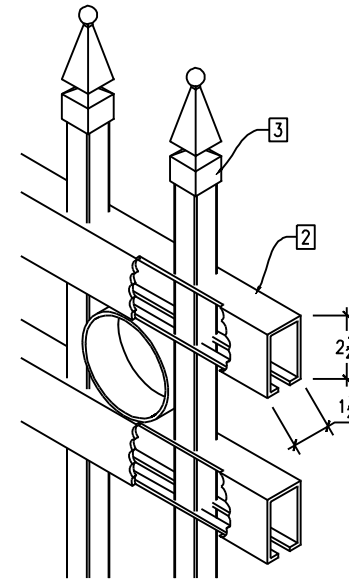

## NOTES:

1. POTEAUX 3" x 3" 14 GAUGE.  
POST 3" X 3" GALVALUME 14 GAUGE.
2. TRAVERSE DE RAIL PERFORÉE 14 GAUGE  
2 ½" x 1 ½" GALV.  
RAIL 2 ½" X 1 ½" PIERCE RAILING GALVALUME 14 GAUGE.
3. BARROTINS 1" x 1" 18 GAUGE GALV.  
VERTICAL PICKETS 1" X 1" GALVALUME 18 GAUGE.
4. SOUDURE STAINLESS  
STAINLESS STEEL WELD.
5. SYSTÈME D'ATTACHE OASIS GALV.  
(FERRURE)  
OASIS FENCE FITTING SYSTEM GALVALUME
6. REVÊTEMENT DE POUDRE POLYESTER  
POLYESTER POWDER COATING.
7. CUISSON AU FOUR  
OVEN BAKED

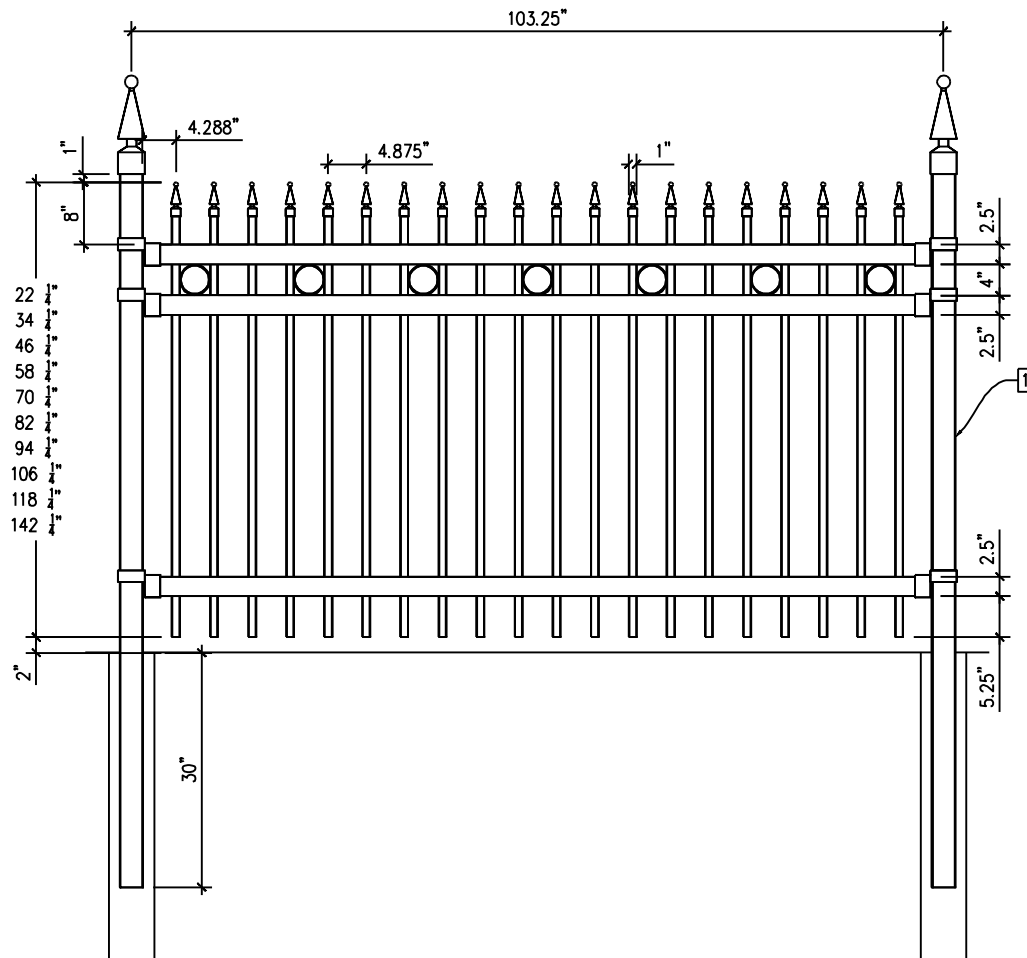

209, rue St-Jean  
Lachute, ( Québec ) J8H 3R8  
Tél.: (450) 562-4780  
Fax: (450) 562-8161

Projet: DESSIN TECHNIQUE  
PROJECT: TECHNICAL DRAWING

Titre: CLÔTURE OASIS / OASIS FENCE  
TITLE: SERIE 9000, MODÈLE 9807

Échelle :	Dessiné par :	Date:	No.
AUCUNE	C.M.	2019-05-09	